

TFC 400

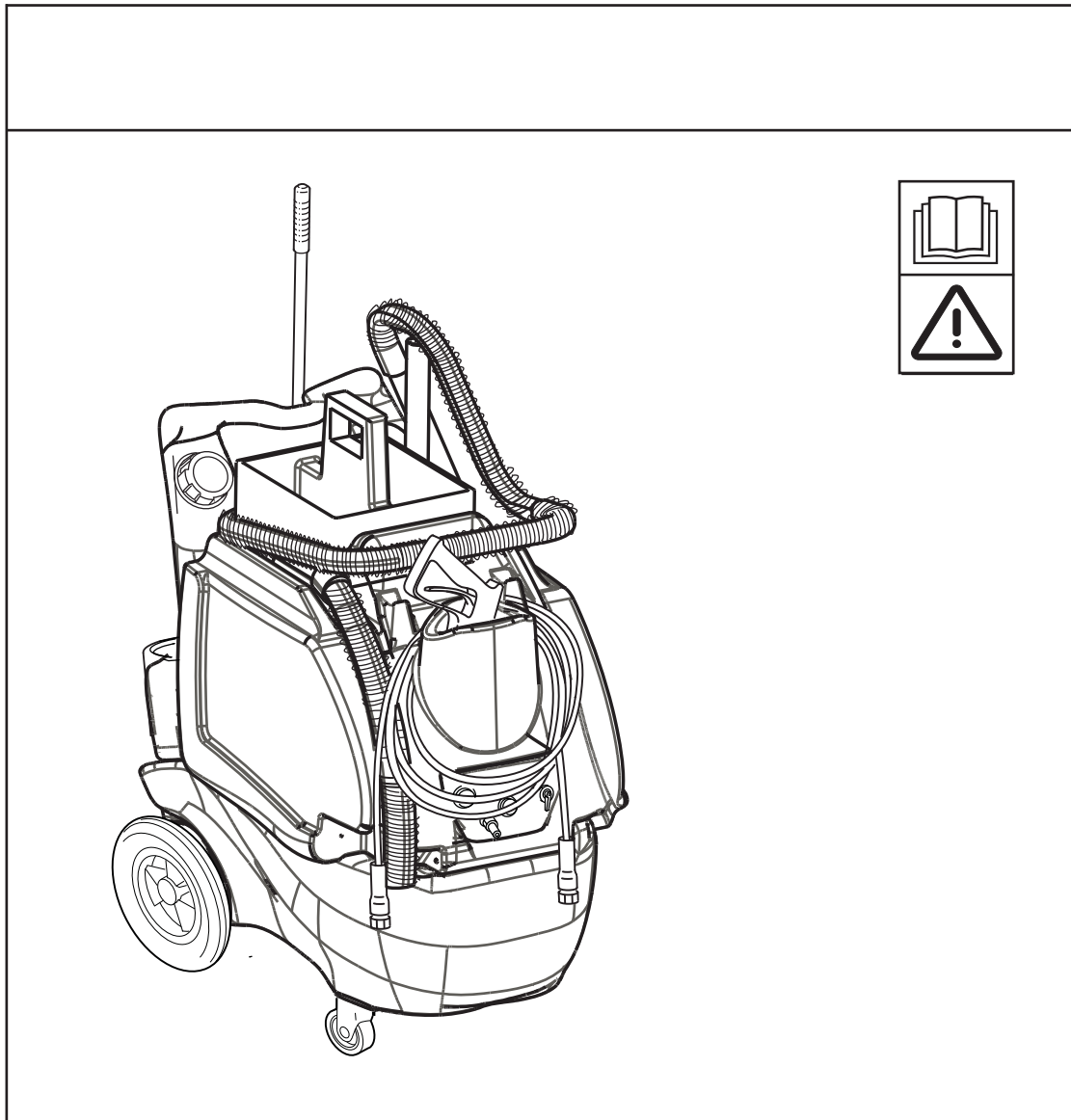

OPERATOR MANUAL
Clarke MODEL 56380773

Clarke[®]

IMPORTANT SAFETY INSTRUCTIONS

This machine is only suitable for commercial use, for example, in hotels, schools, hospitals, factories, shops, and offices other than normal residential housekeeping purposes.

When using an electrical appliance, basic precautions should always be followed, including the following:

READ ALL INSTRUCTIONS BEFORE USING THIS MACHINE.

WARNING

To reduce the risk of fire, electric shock, or injury:

- Always use the power cord that comes with the machine and includes a GFCI (Ground Fault Circuit Interrupter). Never use the machine without connecting to power through a GFCI.
- Do not leave the machine when it is plugged in. Unplug the unit from the outlet when not in use and before servicing.
- To avoid electric shock, do not expose to rain or snow. Store and use indoors.
- Do not allow to be used as a toy. Close attention is necessary when used near children.
- Use only as described in this manual. Use only the manufacturer's recommended attachments.
- Do not use with a damaged cord or plug. If the appliance is not working as it should, has been dropped, damaged, left outdoors, or dropped into water, return it to a service center.
- Do not pull by the cord, use the cord as a handle, damage the cord, or allow the cord or the machine near heated surfaces.
- Do not unplug by pulling on the cord. To unplug, grasp the cord end.
- Do not handle the plug, the cord, or the machine with wet hands.
- Do not put any objects into openings. Do not use with any opening blocked; keep free of dust, lint, hair, and anything that may reduce air flow.
- Keep loose clothing, hair, fingers, and all parts of your body away from the openings and moving parts.
- Do not pick-up anything that is burning or smoking, or any health endangering dusts.
- Turn off all controls before unplugging.
- Always use chemicals with a pH between 4 and 12, and never introduce the chemicals in the tank. Always use the chemical siphoning system.
- Use extra care when cleaning on stairs.
- Do not use to pick up flammable or combustible liquids, and do not use in any areas where these may be present.
- If foam or liquid comes out with the vacuum exhaust, switch the power off immediately. Verify that there are not foreign objects from preventing the float ball from moving freely. Contact Clarke if the problem persists.
- Liquid ejected at the spray nozzle could be dangerous as a result of its temperature, pressure, or chemical content.

SAVE THESE INSTRUCTIONS

INTRODUCTION

This manual will help you to get the most from your Clarke All Purpose Cleaner. Read it thoroughly before operating the machine.

This product is intended for commercial use only.

PARTS AND SERVICE

Repairs, when required, should be performed by Clarke service personnel using original replacement parts and accessories. Call Clarke for repair parts or service.

Please specify the Model and Serial number when calling about your machine.

NAME PLATE

The model and serial number of your machine are shown on the Name Plate on the machine.

This information is needed when ordering parts for the machine.

Use the space below to note the model and serial numbers of your machine.

MODEL NUMBER/NAME: _____

SERIAL NUMBER: _____

NAME AND PHONE NUMBER OF YOUR DISTRIBUTOR: _____

UNPACKING

When the machine arrives, carefully inspect the shipping carton and the machine for damage. If damage is evident, save the shipping carton so that it can be inspected by the carrier.

Contact the Clarke customer service department immediately to file a freight damage claim.

DO NOT OPERATE THE MACHINE UNTIL YOU HAVE READ THIS SECTION IMPROPER USE WILL VOID THE WARRANTY

- Always use a defoamer when foaming occurs to prevent vacuum motor damage.
- To keep fittings, pumps, and lines from damage during freezing conditions, use RV anti-freeze in the pump or keep the machine inside heated areas.
- Do not let the pump run dry.
- All chemicals should be added through the feed system and NOT in the tank.
- All extension cords must have a rating of at least 12/3 (12 gauge cord). Extension cords should be no longer than 50 feet. Replace the plug immediately if the ground prong becomes damaged or is broken off.
- DO NOT use water heated to greater than 120 °F (50 °C).

KNOW YOUR MACHINE DESCRIPTIONS

Operator Handle (1): Operator holds onto this handle to move the machine from one location to another.

Solution Tank Lid (2): This lid screws off so the tank can be filled. The solution fill hose is tethered to the lid, and hangs inside the arm of the Operator Handle.

Tools & Accessories (3): Various accessories can be stored on the machine.

Basket (4): This lift-off carrying basket sits on top of the round lid on the Recovery tank.

Recovery Hose (5): Waste water is picked-up through this hose.

Chemical Container Holders (6): Two molded-in bottle holders for chemical jugs.

Spray Hose (7): This hose delivers water from the machine to the cleaning tool.

Drain Hose (8): This hose is used to empty the recovery tank. NOTE: hold the end of the hose above the water level in the tank to avoid sudden, uncontrolled flow of waste water when you remove the cap, then lower the hose slowly to control the rate of discharge.

Quick Disconnect (9): Point of attachment for the Spray Hose (7).

Switch Plate (10): The machine's on/off switches for the vacuum and for the pump are located here and this is where the valve to change chemical feeds is located.

Castors and Wheels (11): Castors pivot for ease of steering, and large back wheels make it easy to roll the machine from location to location.

Switch Plate (10): The machine's on/off switches for the vacuum and for the pump are located here and this is where the valve to change chemical feeds is located.

Power Cord (12): The 25 ft. power cord connects to a power cord pigtail on the rear of the machine.

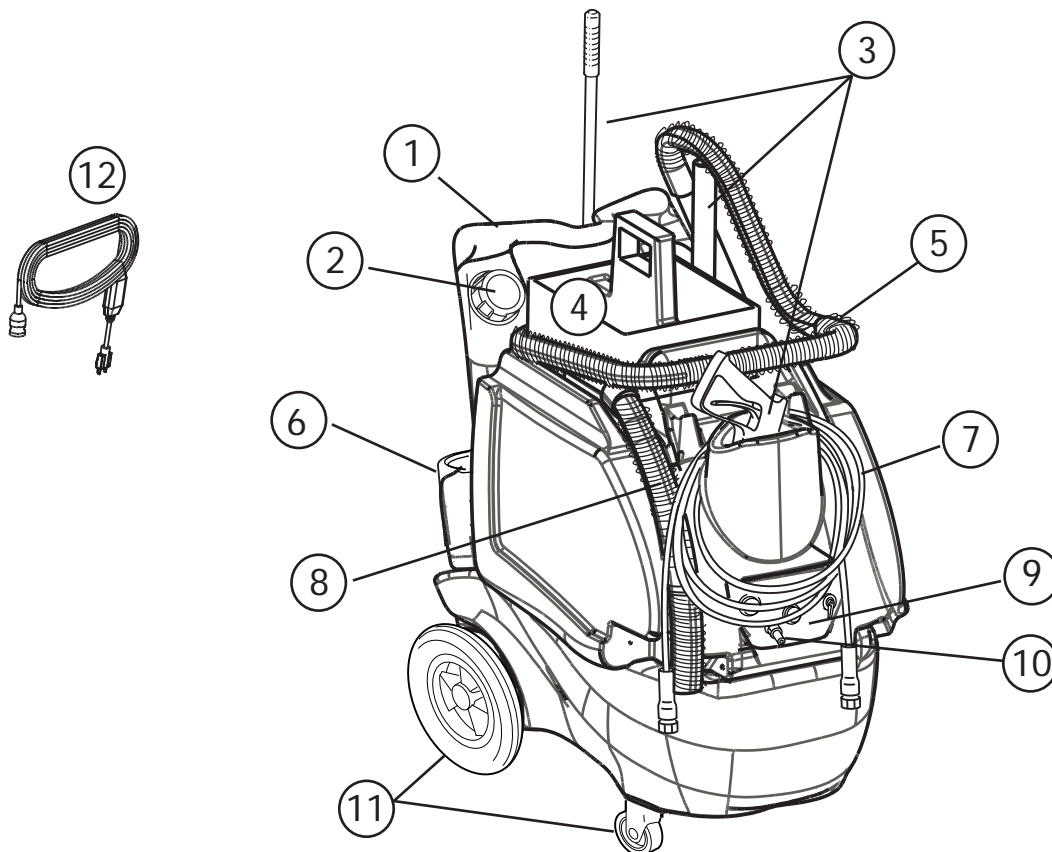

KNOW YOUR SWITCH PLATE

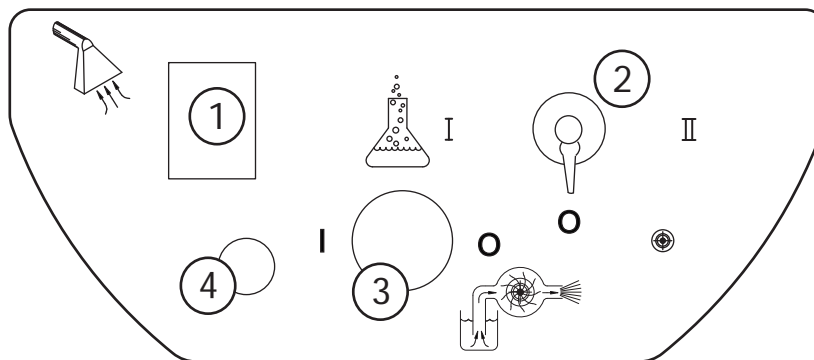

Vacuum Switch (1): turns on the vacuum motor.

Chemical Valve (2): switches between the two chemical containers. When the selector is pointed straight down, the valve is off and neither chemical is selected. When the selector is pointed directly towards one or the other symbols, that chemical is selected.

Solution Pump Switch (3): turns on the solution pump.

Quick Connect (4): this is where solution comes out of the machine and the attachment point for the solution hose.

METERING TIPS

The chemical metering tips allow you to select the ratio of chemical to water, as the water flows out of the machine. Insert the correct metering tip for the desired mixture into the chemical siphon tube.

METERING TIPS			
COLOR	HOLE SIZE	MIX RATIO	FLOW RATE
Orange	0.007	1 oz : 128 oz	1.0 oz/gal
Pink	0.012	1 oz : 64 oz	2.5 oz/gal
Dark Green	0.014	1 oz : 50 oz	3.0 oz/gal
Yellow	0.016	1 oz : 32 oz	5.0 oz/gal
Light Blue	0.020	1 oz : 20 oz	6.0 oz/gal
Burgundy	0.022	1 oz : 15 oz	9.0 oz/gal
Black	0.048	1 oz : 5 oz	20 oz/gal

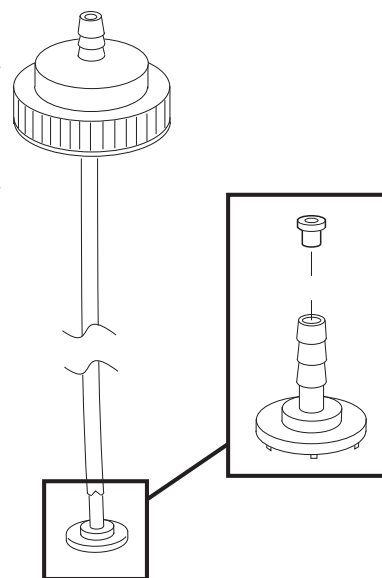

OPERATION

- 1) Insert the appropriate metering tips into the chemical feed lines (see illustration, page 5).
- 2) Fill the holding tank with warm water (not exceeding 120 °F). **Do not** add any chemical to the tank.
- 3) Prepare the area for cleaning by emptying waste receptacles, clearing debris, removing paper products, blowing out vents, and sweeping floors.
- 4) Connect the 25 ft power cord to the pig-tail on the rear of the machine. Test the GFCI on the power cord before each use. Plug the GFCI protected power cord into an outlet.
- 5) **PRIME THE PUMP:** Attach the priming hose to the outlet quick disconnect and place the open end of the hose into the recovery tank. Turn on the pump and let it run until the pump is completely primed (no visible air in the water stream). Turn the pump off.
NOTE: prime the machine before you place the chemical feed tubes into chemical containers.
- 6) Disconnect the priming hose and attach the solution hose to the quick disconnect.
- 7) Attach the spray gun to the other end of the solution line.
- 8) Place chemicals in the molded-in chemical bottle containers on the rear of the machine. Insert one of the feed lines into one of the chemical containers. Secure the line by screwing on the cap. The chemical will feed from which ever container the selector valve on the switch plate is turned towards and when the gun is used in the low pressure setting. Use chemicals with a pH of between 4 and 12. Never add chemicals to the clean water tank.
- 9) Set the spray gun to low pressure by sliding the pressure selector forward (low pressure = forward; high pressure = back).
- 10) Turn on the pump switch (push button) and spray through the gun for a few seconds to fill the line with solution.
- 11) Apply the chemical to the walls and fixtures from the bottom up. Spray the floor last as you work your way out of the room.
- 12) Allow the chemical to work for the proper amount of dwell time, according to the chemical manufacturer's directions. Agitate heavily soiled areas with a scrub brush.
- 13) Turn off the chemical injector valve by turning the selector to the down position.
- 14) Set the spray gun to high pressure and rinse the area from the top down.
- 15) Connect the vacuum hose, attach the squeegee, and turn on the vacuum (rocker switch).
- 16) Squeegee off the mirrors, pick up the liquid off the floor with the floor tool. If you have the optional blow dry hose, use it to dry the fixtures.
- 17) Drain the recovered water into a utility sink or toilet. **NOTE:** Keep the top of the drain hose higher than the water level in the tank to avoid uncontrolled discharge of water when you open the cap on the hose.

CAUTION

To avoid vacuum motor damage, always use a defoamer any time foam is present. Before you turn on the vacuum always make sure the filter screen on the ball float is clean and that the ball can travel freely.

RE-PRIMING THE PUMP

If the pump loses prime between jobs, follow the instructions to PRIME THE PUMP, above. If that doesn't get water flowing, put the priming hose into the vacuum inlet hose barb and cover the rest of the space around the priming hose with your hand. Turn on the vacuum (with the pump also running) and let the suction of the vacuum assist in getting water into the pump.

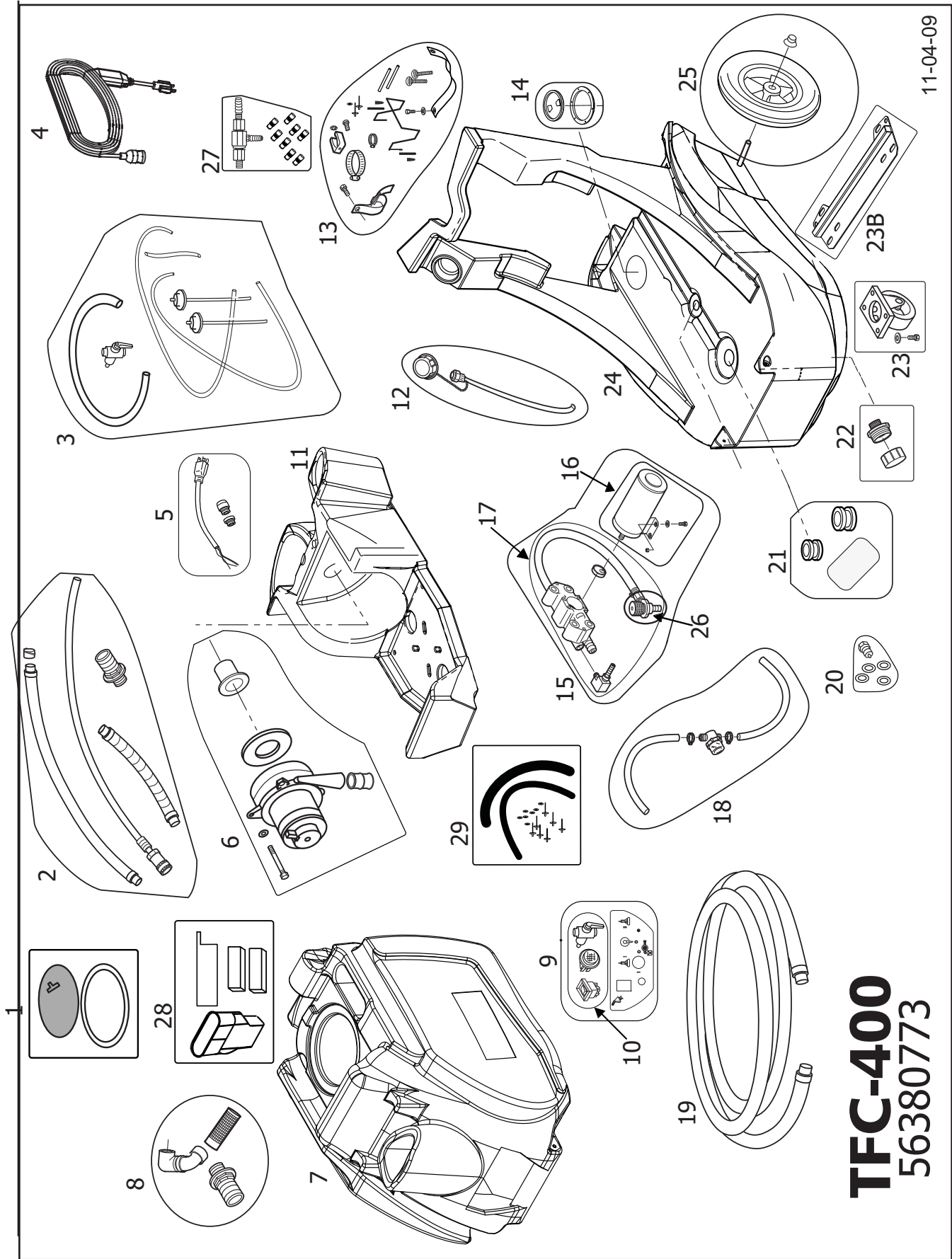

11-04-09

TFC-400
56380773

PART LIST

<u>ITEM</u>	<u>PART No.</u>	<u>QTY</u>	<u>DESCRIPTION</u>
1	56380907	1	Lid and gasket, recovery tank
2	56380780	1	Hose kit, drain, priming and vac inlet
3	56380782	1	Hose kit, water inlet and chemical metering
4	56380774	1	Power cord, 25 ft, with GFCI
5	56380783	1	Pig Tail, for Power cord, with cord retainer
6	56380909	1	Vacuum motor kit, with gasket and hose
7	56380912	1	Tank, Recovery, complete
8	56380924	1	Vacuum inlet kit
9	56380919	1	Switch plate kit, complete
10	56380939	1	Switch kit, three switches
11	56380930	1	Pallet, component mounting, empty *
12	56380793	1	Lid, with fill hose, holding tank/base
13	56380843	1	Fasteners kit
14	56380841	1	Lid and ring, 4"
15	56380923	1	Pump and motor, 400 psi, complete
16	56380908	1	Motor, DC, pump drive
17	56380902	1	Pump, 400 psi, complete, no motor
18	56380929	1	Filter, pump in-line, with hoses
19	56380805	1	Hose, vacuum, 25 ft, complete with cuffs
20	56380787	1	Quick disconnect kit, with washers
21	56380934	1	Grommets and foam
22	56380797	1	Cap, drain, and brass fitting
23	56380798	1	Castor kit
23B	56380894	1	Castor/Squeegee mounting plate
24	56380935	1	Holding tank/base
25	56380799	1	Wheel kit
26	56380925	1	Pressure regulator, for 400 psi pump
27	56380913	1	Chemical Injector and Metering Tip kit
28	56380940	1	Gun sleeve and gaskets
29	56380941	1	Seals and rivets, for switch plate

MISCELLANEOUS PARTS

56380921	Label kit, "TFC 400" & warning
*56380928	Pallet assembly with components, complete

REV C 11-2009

TOOLS

Tool Kit, standard, complete -- # 56380937

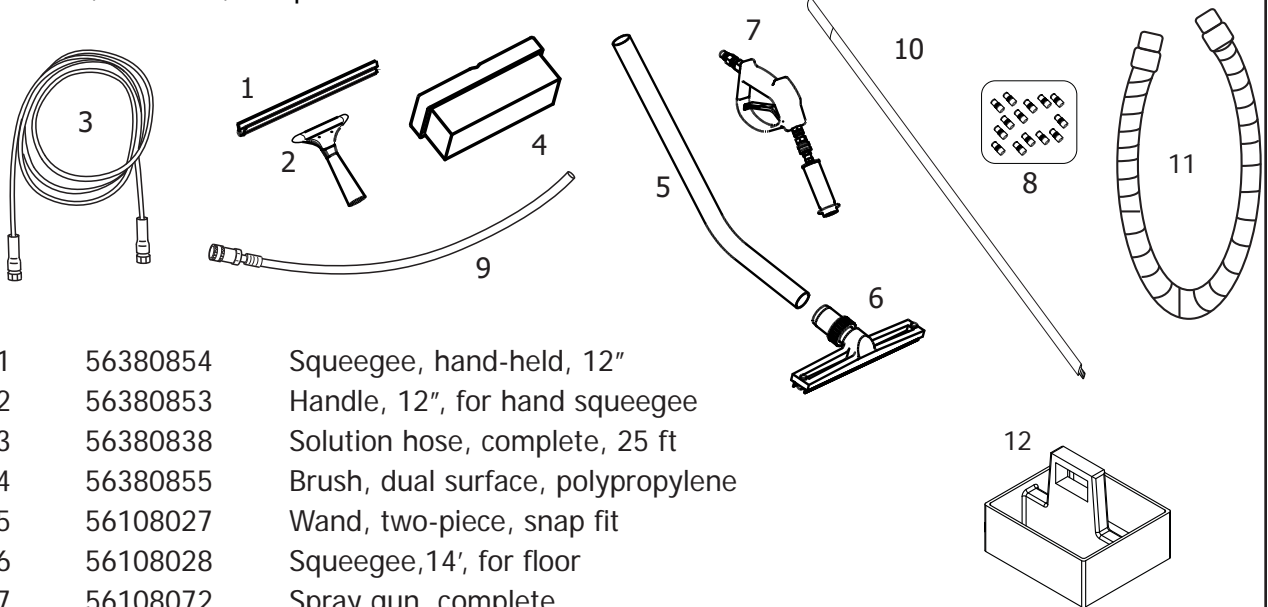

- | | | |
|----|----------|---|
| 1 | 56380854 | Squeegee, hand-held, 12" |
| 2 | 56380853 | Handle, 12", for hand squeegee |
| 3 | 56380838 | Solution hose, complete, 25 ft |
| 4 | 56380855 | Brush, dual surface, polypropylene |
| 5 | 56108027 | Wand, two-piece, snap fit |
| 6 | 56108028 | Squeegee, 14', for floor |
| 7 | 56108072 | Spray gun, complete |
| 8 | 56380802 | Metering tip kit, two each of seven sizes |
| 9 | 56108024 | Priming hose assembly, for 400 psi pump |
| 10 | 56380852 | Handle, black, 54" |
| 11 | 56380805 | Recovery hose, 25 ft |
| 12 | 56380938 | Tote box |

OPTIONAL ACCESSORIES

- | | | |
|---|----------|---|
| 1 | 56380856 | Mop frame |
| 2 | 56380857 | Mop, microfiber, package of six |
| 3 | 56380888 | Squeegee assembly, 24" |
| 4 | 56209089 | Squeegee assembly, 30" |
| 5 | 56380871 | Mount assembly, mechanical, for squeegee head |
| 6 | 56380877 | Blower hose assembly, with nozzle |

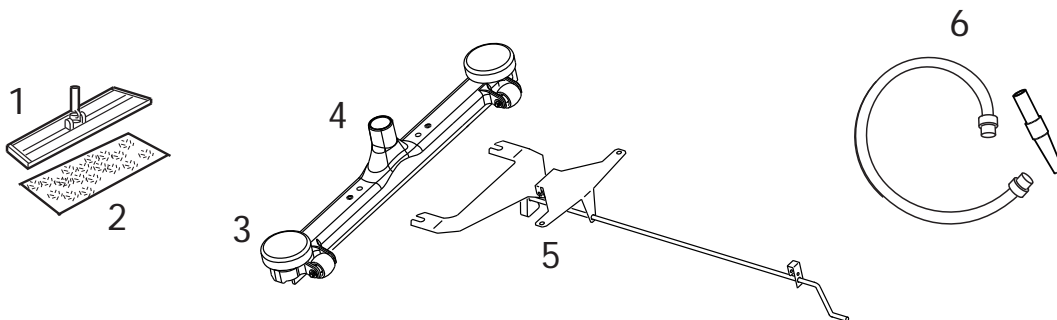

MAINTENANCE

- 1) Use only approved chemicals at the recommended mix ratios. All chemicals should be added through the feed system and NOT added directly to the water in the solution tank to prevent possible damage to the pump, seals, or other components.
- 2) For optimum performance, flush the Chemical Feed lines after every job by replacing the chemical containers with containers of clear water and spraying through the gun until the fluid stream is clear. See the Maintenance Schedule, below.
- 3) The pump seals and/or valves in the high pressure pumps may need to be replaced after about 1000 hours of use, if the pump begins to lose performance or to leak. The pressure regulator valve may need to be replaced when a drop in the spraying pressure at the tool is apparent.
- 4) If the 4", clear lid is removed from the top of the base (solution tank), you will need to apply a silicone sealant to the threads when you reinstall the lid to seal for vacuum leaks.

MAINTENANCE SCHEDULE				
ITEM	DAILY	WEEKLY	QUARTERLY	YEARLY
Flush chemical lines	X			
Check/clean vac inlet filter	X			
Clean solution filter		X		
Check vacuum motor airways		X		
Check pump for leaks			X	
Check vacuum motor brushes *				X

* Have Clarke check the carbon brushes once a year or after about 500 hours of operation.

TECHNICAL SPECIFICATIONS

Vacuum motor:	2-stage, 8 amp
Water lift:	97"
Air flow:	100 CFM
Tank construction:	Rotationally molded polyethylene
Solution tank capacity:	20 gallon
Recovery tank: capacity:	13 gallon
Application flow:	400 psi
Vac & Solution hose length:	25 feet
Power cord:	25 feet
Height:	38.5 inches
Width:	21.25 inches
Length:	34 inches
Machine weight:	92 lbs

NOTES:

Clarke® U.S. WARRANTY

This Clarke Industrial/Commercial Product is warranted to be free from defects in materials and workmanship under normal use and service for a period of three years from the date of purchase, when operated and maintained in accordance with Clarke's Maintenance and Operation instructions. This warranty is extended only to the original purchaser for use of the product. It does not cover wear parts such as electrical cable, rubber parts, hoses, and motor brushes.

If difficulty develops with the product, you should:

- (a) Contact the nearest authorized Clarke repair location or contact Clarke Service Operations Department 14600 21st Avenue North, Plymouth, MN 55447, for the nearest Clarke repair location. Only those locations are authorized to make repairs to the product under this warranty.
- (b) Return the product to the nearest Clarke repair location. Transportation charges to and from the repair location must be prepaid by the purchaser.
- (c) Clarke will repair the product or replace any defective parts without charge within a reasonable time after the receipt of the product.

Clarke's liability under this warranty is limited to repair of the product and/or replacement of parts and is given to the purchaser in lieu of all other remedies, including INCIDENTAL AND CONSEQUENTIAL DAMAGES.

THERE ARE NO EXPRESS WARRANTIES OTHER THAN THOSE SPECIFIED HEREIN. THERE ARE NO WARRANTIES WHICH EXTEND BEYOND THE DESCRIPTION OF THE FACE HEREOF. NO WARRANTIES, INCLUDING BUT NOT LIMITED TO WARRANTY OF MERCHANTABILITY, SHALL BE IMPLIED. A warranty registration card is provided with your Clarke product. Return the card to assist Clarke in providing the performance you expect from your new machine.

CLARKE®, 14600 21st Avenue North, Plymouth, MN 55447

Clarke® reserves the right to make changes or improvements to its machine without notice.

Always use genuine Clarke® parts for repair.

Clarke®

14600 21st Avenue North
Plymouth, MN 55447